

# Recommended Enclosures

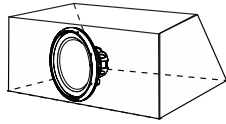

sealed

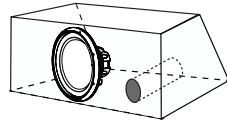

ported

## QW5000/12D4

### Sealed Enclosure

Box Volume 1.40 cu ft.

### Ported Enclosure

Box Volume 2.48 cu ft.

Box Tuning 39Hz

Port Diameter 4in

Port Length 6in

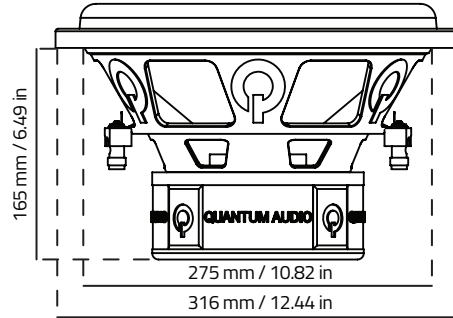

## QW5000/15D4

### Sealed Enclosure

Box Volume 2.33 cu ft.

### Ported Enclosure

Box Volume 2.95 cu ft.

Box Tuning 39Hz

Port Diameter 6in

Port Length 13in

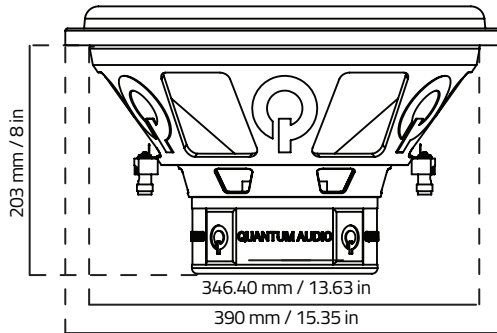

Please Note: Our suggested box volumes are given as internal air requirements



# QW5000/12D4 - QW5000/15D4

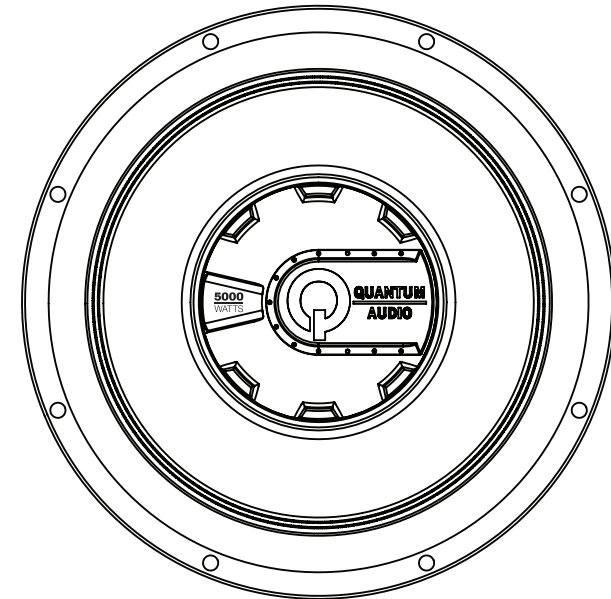

DB Research L.L.P. • 302 Hanmore Industrial Parkway • Harlingen, TX 78550

ph: 877.787.0101 • fx: 956.421.4513 • www.dbdrive.net • tech Support: support@dbdrive.net

## USER MANUAL

Installation Instructions | Owners Manual

Due to continuous improvement of the product, specifications are subject to change without notice.

## INTRODUCTION

Congratulations on your purchase of a Quantum Audio state-of-the-art subwoofer component. Your selection of a Quantum Audio car audio product indicates a true appreciation of fine musical reproduction. Whether adding to an existing system or including a Quantum Audio subwoofer in a new system, you are certain to notice immediate performance benefits.

## KEEP YOUR SALES RECEIPT

Take this time to attach your sales receipt to the manual and put in a safe place. In case of any unforeseen reason this product may need warranty service, your receipt will be necessary to establish purchase date. For detailed warranty information please refer to enclosed warranty card.

## RECOMMENDATION

A speaker's performance is only as good as it's enclosure. Proper installation, enclosure size and crossover frequency will maximize the overall performance of the subwoofer. To properly design and build an enclosure, knowledge of woodworking as well as the proper tools are required. We highly recommend that you have your enclosure built by an authorized Quantum Audio retailer. However, if you decide to install it yourself, we have included the parameters of each driver and recommended enclosure sizes. If after reviewing the enclosed information you have any addition questions, please feel free to contact our technical dept.

## WARNING!

Exposure to high pressure levels can cause hearing loss or damage. Listening to your system at loud levels while driving, will impair your ability to hear traffic sounds and emergency vehicles. Use common sense when listening to your system.

While installing your subwoofer enclosure in the vehicle. Securely fasten it to the frame or floorpan. If the enclosure is not secured properly, there is danger of it becoming a projectile in a collision.

Due to continuing product improvement, specifications and design are subject to change without notice.



## PRODUCT SPECIFICATIONS

	QW5000/12D4	QW5000/15D4
(Re)	6.8 $\Omega$	6.8 $\Omega$
(fo)	40.84 Hz	37.82 Hz
(BL)	24.32 N/A	25.99 N/A
(Qms)	1.927	2.205
(Qes)	0.752	0.946
(Qts.)	0.541	0.662
(Vas)	23.84L	43.75L
(Cms)	59.562u mm/N	44.775u mm/N
(Mms)	254.973 gr	395.319 gr
(Sens.)	87.5 dB	86.8 dB
(Xmax)	0.60in	0.60in

## CALCULATING ENCLOSURES

It is difficult to give exact box dimensions that are universal for all cars and trucks. It is for this reason that you must be able to calculate the space in which you have available in order to achieve the proper air volume required.

It is recommended to build your enclosure from 3/4" thick MDF (medium density fiberboard). Make sure the enclosure is sealed airtight.

### Calculating External Volume

- 1.) To calculate box volume, measure the outside Width x Height x Depth of the enclosure. *Example 12" x 14" x 9" = 1512 ÷ 1728" Cubic feet*
- 2.) Next you must convert cubic inches into cubic feet. To do this, you must divide the cubic inches total by 1728". *Example 1512 ÷ 1728 = .875 Cubic feet*

### Calculating Internal Volume

- 1.) To calculate the internal (net) volume of the above box you must first multiply the thickness of the wood you are using by Two(2). *Example 3/4" x 2 = 1.5"*
- 2.) Next subtract 1.5 from each of the outside measurements of the box.

Width	Height	Depth
12 - 1.5 = 10.5	14 - 1.5 = 12.5	9 - 1.5 = 7.5
- 3.) Multiple the new totals (H x W x D) *Example: 10.5 x 12.5 x 7.5 = .5696*
- 4.) Next you must convert cubic inches into cubic feet. To do this, you must divide the cubic inch total by 1728". *Example 984.375 ÷ 1728 = .5696 cubic feet.*